

CANDIDATE'S NAME _____

**CHURCH OF THE ANNUNZIATA
2020 CONFIRMATION WORKBOOK
CALLED TO WITNESS**



LIVING THE SACRAMENTAL COMMITMENT

INTRODUCTION

Dear Confirmation Candidate,

A warm welcome to you as you begin your journey toward the Sacrament of Confirmation. This Sacrament completes the Sacraments of Initiation, which are Baptism, Eucharist, and Confirmation. As is said in the Youth Catechism: “Baptism joins us with Christ. Confirmation gives us His Spirit” (YOUCAT 193) and the Confirmand “receives the strength to witness to God’s love and might in words and deed” (YOUCAT 203).

This sacrament is extremely important and Annunziata wishes for you to be fully prepared. In the coming months, you will journey with others and share your own experiences and questions about your faith. You will see Confirmation as an important commitment. This sacrament is not something you simply receive, but it is a sacrament you *live*.

Preparation for Confirmation is the process of realizing that God chose you first. God made you unique with special gifts. At the moment of your Confirmation, it is essential that YOU, as a young adult, have entered it freely and without pressure. Therefore, it is also essential that YOU, as a young adult, make the decision to pursue Confirmation. Mom, Dad, or your friends should not make this decision.

YOU need to decide if you are willing to:

- 1) Live as a committed Catholic Christian;
- 2) Continually nurture and grow in faith;
- 3) Put into practice what Jesus taught us.

Confirmation is not a single moment, but a beginning. It is an opportunity for you to continue to develop your faith; work to make a better Church, participate, make a change and remember the Greatest Commandment: “Love the Lord your God with all your heart and love your neighbor as yourself.”

Welcome to the journey!

CONFIRMATION PREPARATION PROCESS

GUIDELINES AND EXPECTATIONS

The workbook is designed to complement the candidate’s classroom instruction as presented by his/her catechist, Mr. John Cronin.

This workbook consists of faith enrichment assignments/projects to be completed at the candidate’s own pace. Each assignment/project is explained in detail throughout the workbook. Read through it all and plan out your journey. Working together with parents and/or sponsors on the assignments/projects in this workbook can be especially beneficial and wonderful.

While all assignments/projects have specific due dates, they may be done in any order. *You are encouraged to work ahead.*

Workbooks are to be turned in, with designated assignments/projects completed, for review by either Mr. Cronin or Mrs. Laura Gyawali, PSR Principal, on the following dates:

<u>DUE DATE</u>	<u>PROJECTS COMPLETED</u>
Due: Sunday, February 23 rd	Projects # 1, 2, 5-I, 6
Due: Sunday, April 5 th	Projects # 3, 4, 7, & 9
Due: Sunday, April 19 th	Confirmation Sponsor Form & Confirmation Information Form
Due: Sunday, April 26 th	Projects # 5-II, 8, 10, & 11

*In order to complete the Confirmation preparation process, all workbooks must be **completed and submitted by April 26, 2020.***

RECEIVING THE SACRAMENTS

The Sacraments of the Eucharist and Reconciliation are two of the few sacraments that we may receive more than once in our lifetime. Both the Eucharist and Reconciliation are wonderful experiences of God's love and mercy for each of us.

Receiving Jesus in the sacrament of the Eucharist keeps the light and love of Christ within us and strengthens our abilities to live the gifts and fruits of the Holy Spirit. Jesus said, "Whoever eats my flesh and drinks my blood has eternal life, and I will raise him on the last day."

Many young people say that receiving God's mercy in the sacrament of Reconciliation lifts the burdens of their hearts. Jesus told his apostles, "Whose sins you forgive, they are forgiven..." This established the apostles, and today, priests, as the representatives within the Christian family invested with the power of forgiving sins in Jesus' name.

Annunziata celebrates the Sacrament of the Eucharist during Mass on:

- Sundays at 7:00, 9:00, and 11:00 a.m.;
- Mondays - Fridays at 7:00 and 7:45 a.m.;
- Saturdays at 7:00 and 9:00 a.m. and 5:00 p.m.

NOTE:

All candidates are expected to regularly attend and participate in Mass and must complete three homily reflections as part of this Confirmation Preparation Workbook.

Annunziata offers the Sacrament of Reconciliation:

- on Saturday afternoons 4:00 to 4:45 p.m.;
- on the last Sunday of the month after all the Sunday morning Masses;
- or anytime by calling one of your priests.

Each Confirmation candidate is strongly encouraged to celebrate this sacraments of Christ's Body and Blood in the Eucharist and God's healing forgiveness in Reconciliation throughout the semester and their entire lives. The class will attend Reconciliation during two class meeting prior to Confirmation on Sundays, February 9 and April 19.

PROJECT # 1

BAPTISM

DUE: FEBRUARY 23rd

In the sacrament of Baptism, the Church welcomes children and adults into the faith community. In infant Baptism, the priest or deacon asks the parents, “What do you ask of God’s Church for your child?” The response to this is “faith,” “baptism,” and “entrance into the community of faith.”

The gift of faith comes to you from God through the Church and the community of believers, your family, and the parish family. The gift of faith must be accepted if it is to be truly a gift for you. At Baptism, your parents and godparents accepted this gift in your name. They promised to nurture you in the faith of the Church and help you to understand this gift by their lived example, so that one day you would be able to accept it yourself.

The sacrament of Baptism is the first step of our faith journey. It is probably one of the most important steps of that journey.

Ask your parents to tell you about the day you were baptized. What were their hopes and dreams for you in faith? Ask for a copy of your baptismal certificate and please attach a copy to the back of the next page. Also, please fill in the following information:

BAPTISMAL NAME: _____

CHURCH OF BAPTISM: _____

DATE OF BAPTISM: _____

PRIEST OR DEACON: _____

SPONSORS/GODPARENTS: _____

- 1) Ask your parents to write a letter to you stating how they will continue their promise, made at your baptism, to help you grow in faith and in love of God. (Attach it to the next page.)
- 2) Ask one of your godparents to write a brief note to you about how they feel about being your godparent. (Attach it to the next page.)
- 3) Ask your parents why they gave you the name they gave you. Was it in honor of a family member or a favorite saint? Write about who you are named for on the next page.
- 4) Staple all your letters and the copy of your Baptismal Certificate to the following page.

PROJECT # 2

CONFIRMATION SPONSOR

DUE: FEBRUARY 23rd

During the preparation for the reception of the Sacrament of Confirmation, each candidate must choose a sponsor. A sponsor's role is that of one companioning the candidate throughout the preparation time.

In choosing a sponsor, the Church's law gives us some requirements that must be met:

- A sponsor must be at least sixteen years old;
- A sponsor must be a fully initiated Catholic (one who has celebrated Baptism, Eucharist, and Confirmation) who "leads a life in harmony with the faith and the role to be undertaken;"
- A sponsor must not be bound by any Church penalty (i.e. married outside the Church, civilly married, divorced and remarried without an annulment);
- A sponsor must not be a parent of the one to be confirmed.

It is also important to reflect on the following characteristics when choosing a sponsor:

- Local residency, to ensure consistent involvement throughout the Confirmation process;
- A positive and comfortable relationship with the candidate;
- A willingness and capacity to engage in the Confirmation process as a means of enhancing his/her own growth as a Catholic Christian adult.

The person you choose for your sponsor should be willing to participate with you in the preparation for the sacrament. If they are not able to, you may consider choosing someone to act as a "proxy" for the preparation period. Inviting your sponsor to Reconciliation, Mass, community service and faith enrichment projects, and the REAP Retreat (sponsors are required to attend with you on Saturday, April 25th) will give him/her an opportunity to join you during this journey, rather than just having him/her "check up" on you about fulfilling your obligations.

When you choose a sponsor for Confirmation, you will look to someone who will be a good listener, a guide, and a confidant; a person who is interested in not only your growth as a Christian, but willing to grow in faith along with you.

If you are still in the process of choosing a sponsor, use the discernment worksheet on page 9 to reflect on two or three people you would consider.

PROJECT # 2

SPONSOR INTERVIEW

DUE: FEBRUARY 23rd

The Sacrament of Confirmation is the final initiation for each candidate into the Catholic Church. Being fully initiated means becoming involved in the community of faith.

As an opportunity to become more aware of the impact of the Sacrament of Confirmation, candidates must be asked to interview their sponsor about their faith lives.

Here are some suggestions for the interview:

- What does being Catholic mean to you?
- How do you practice your faith?
- How do you keep an active prayer life? Do you have a favorite prayer?
- Do you remember your Confirmation? How do you think it has impacted your life?
- Who is your Confirmation saint? Why did you choose him/her?
- Create your own questions...

Please type a summary of your interview and attach it to this page.

SPONSOR INTERVIEW

SPONSOR (FIRST, MIDDLE, LAST): _____

SPONSOR'S PARISH: _____

RELATIONSHIP TO CANDIDATE: _____

DATE OF INTERVIEW: _____

NOTES: _____

PROJECT # 2
CHOOSING A CONFIRMATION SPONSOR WORKSHEET

DUE: FEBRUARY 23rd (OPTIONAL)

WHOM MIGHT YOU CHOOSE AS YOUR SPONSOR?

NAME: _____ RELATION: _____

CHARACTERISTICS: _____

WHY WOULD YOU CHOOSE HIM/HER? _____

NAME: _____ RELATION: _____

CHARACTERISTICS: _____

WHY WOULD YOU CHOOSE HIM/HER? _____

NAME: _____ RELATION: _____

CHARACTERISTICS: _____

WHY WOULD YOU CHOOSE HIM/HER? _____

PROJECT # 3

GIFTS OF THE HOLY SPIRIT

DUE: APRIL 5th

In Confirmation, you will receive the fullness of the gifts of the Holy Spirit. These gifts help us to be holy. The Seven Gifts of the Holy Spirit are:

WISDOM –

infused gift that gives us delight in the things of God and directs our lives and actions to His honor and glory. Wisdom aligns our souls to God in the contemplation of all things; going beyond simple knowledge and belief to a divine absorption of truth itself.

UNDERSTANDING –

infused gift to allow the mind to grasp revealed truths easily and profoundly with insight into the meaning of these truths, thus helping us order the actions of our lives to God.

KNOWLEDGE –

infused gift to give us the ability to judge everything from a supernatural viewpoint. As a result, we can:

1. see the providential purpose of whatever enters our lives,
2. put creatures to the right use according to God's will for ourselves and others, and
3. discern easily and effectively between the impulses of temptation and the inspirations of grace.

COUNSEL –

infused gift that enable us to determine promptly and rightly what should be done, especially in difficult situations. This primarily refers to our choices/behavior.

FORTITUDE –

infused gift that gives us incredible courage, strength of will, and willingness to undergo difficult trials for the love of God.

PIETY –

infused gift that gives us loyalty to God and the things of God; also enables us to know God as our loving Father and respond to Him with love and obedience.

FEAR OF THE LORD –

infused gift that inspires us to have a profound respect for the divinity and power of God and the desire to never offend or do anything to separate ourselves from Him.

PROJECT # 3

GIFTS OF THE HOLY SPIRIT

DUE: APRIL 5th

Prayer for the Seven Gifts of the Holy Spirit

“Lord Jesus Christ, before ascending into heaven, You promised to send the Holy Spirit to Your apostles and disciples. Grant that the same Spirit may perfect in my life the work of Your grace and love. Grant me the Spirit of **WISDOM** that I may aspire only after the things that are eternal; the Spirit of **UNDERSTANDING** to enlighten my mind with the light of Your divine truth; the Spirit of **KNOWLEDGE** that I may know You and know myself, and grow perfect by the example of the saints; the Spirit of **COUNSEL** that I may choose the surest way of doing Your will, seeking first the Kingdom of Heaven; the Spirit of **FORTITUDE** that I may bear my cross with You and, with courage, to overcome the obstacles that interfere with my salvation; the Spirit of **PIETY** that I may find peace and fulfillment in the service of God; Grant me the Spirit of **FEAR OF THE LORD** that I may be filled with a loving reverence toward You, and may dread in any way to displease You. Mark me, dear Lord, with the sign of Your true disciples and animate me in every way with Your Spirit. Amen.”

QUESTIONS

(Please write your answers on the next pages.

If you need more room, feel free to attach additional pages.)

- 1) Using a Bible, find and record two Biblical passages on **WISDOM** (just references), and give a brief description for each passage of how you can apply this wisdom to your own life.
- 2) Give two examples of how teenagers can grow to **UNDERSTAND** their parents and family members. Also, indicate how they can enhance these relationships by being more understanding.
- 3) Give two examples of how the gift of **KNOWLEDGE** can resolve a social problem, at home and in the world.
- 4) List and explain two attributes that enhance the gift of **COUNSEL**.
- 5) Give one example of how teenagers can use the gift of **FORTITUDE**.
- 6) Describe a person who you think exhibits the gift of **PIETY**. How do they demonstrate **PIETY**? What are his/her qualities? What do you admire about him/her?
- 7) Briefly describe an experience you have had with God that revealed His power.

PROJECT # 3 GIFTS OF THE HOLY SPIRIT

DUE: APRIL 5th

PROJECT # 3
GIFTS OF THE HOLY SPIRIT
DUE: APRIL 5th

PROJECT # 4
LETTER TO THE BISHOP
DUE: APRIL 5th

Write a letter to Reverend Michael P. Boehm, V.G. requesting the Sacrament of Confirmation. Reflect on your readiness to make a “vow.” This 250 to 300 word letter should be typed. **Print a copy and bring it to your catechist, Mr. Cronin.** This assignment should not be taken lightly as it is a summary of your experience and growth during your preparation for confirmation.

During the ceremony of Confirmation, you will be taking on the responsibilities of the promises that were made by your parents and godparents. What do these responsibilities entail? As a Confirmed Catholic, God will be holding you responsible for your choices and actions or lack of action. Reflect on Jesus’ words to The True Disciple, “Not everyone who says to me, ‘Lord, Lord,’ will enter the kingdom of heaven, but only the one who does the will of my Father in heaven.” (Matt 7:21)

Upon accepting the sacrament of Confirmation you will be accepting the spiritual attributes and responsibilities that come along with this sacrament. Are you ready to make this commitment? In this letter, explain why you should be Confirmed. Convince him! Use the space below for notes.

PROJECT # 5, PART I
EUCCHARISTIC ADORATION PRAYER EXPERIENCE

DUE: JANUARY 19TH
(DURING CLASS TIME)

Part One: *Eucharistic Adoration*

Our belief in the true presence of Jesus in the Eucharist--Body, Blood, Soul, and Divinity--is what sets us apart as Catholic Christians. At Mass, the priest, in persona Christi, repeats the words and actions of Jesus at the Last Supper. At that moment, the power of the Holy Spirit sacramentally transforms the species of bread and wine into Christ's body and blood so that we might be united with him. Jesus is our daily bread, our truest source of Life.

At Adoration, Jesus is present in the Blessed Sacrament and placed on the altar in a beautiful Monstrance for us to worship him. Jesus, born of the Virgin Mary, skilled carpenter, and miracle worker; Jesus, crucified, died, and buried; Jesus, resurrected on the third day; Jesus, our Savior, invites us, waits for us, and *longs for us* to spend time with him. Personal time with Jesus is life changing.

ASSIGNMENT

Spend 20 minutes with Jesus in Eucharistic Adoration and write a reflection about your experience.

(Note: Our Eucharistic Adoration Chapel is open Mondays 7:30 a.m. - 8:30 p.m. & Thursdays 1:00 p.m. - 8:00 p.m.

The Carmelite Monastery, located on Clayton Road just East of Price, is open daily from 6:30 a.m. to 8:00 p.m.)

Where did you spend time with Jesus in Eucharistic Adoration? _____

EUCCHARISTIC ADORATION PRAYER EXPERIENCE REFLECTION

PROJECT # 5, PART I
EUCHARISTIC ADORATION PRAYER EXPERIENCE

DUE: JANUARY 19th

(DURING CLASS TIME)

PROJECT # 5, PART II

ROSARY PRAYER EXPERIENCE

DUE: APRIL 26th

Part Two: The Rosary

Our prayers are communion with the Father and the Son through the power of the Holy Spirit. Remember that it is through the Holy Spirit that Jesus came and was born to us here on earth. At the Annunciation, the Angel Gabriel appeared to Mary and told her that she would conceive of a son... She asked, "But, how can this be...?" He answered her, "the Holy Spirit will come upon you..." Mary is the vessel of our salvation and always leads us to her son. Meditation on the mysteries of the rosary takes us on a journey through the life of Jesus and brings us closer to him. While praying the rosary, Mary presents our needs to her son. The rosary is one of the most powerful and recited prayers in our Catholic faith.

ASSIGNMENT

Pray the Rosary, then share your thoughts, impressions, and feelings about the experience.

ROSARY PRAYER REFLECTION

PROJECT # 6
RECONCILIATION

DUE: FEBRUARY 9th

(DURING CLASS TIME)

The Sacrament of Reconciliation is one of the few sacraments that we can receive more than once in our lifetime. It is a wonderful experience of God’s mercy and love for each of us. It is important for all Catholics to participate regularly in this sacrament. Jesus told his apostles, “Whose sins you shall forgive they are forgiven.” This established the apostles, and today, priests, as the representatives within the Christian family invested with the power of forgiving sins in Jesus’ name. Each Confirmation candidate is strongly encouraged to celebrate this great sacrament of God’s healing forgiveness and love *often* during the course of his/her journey.

All Candidates will receive the Sacrament of Reconciliation during class on February 9th and April 19th.

YOUR THOUGHTS, IMPRESSIONS, AND COMMENTS ABOUT THE SACRAMENT OF RECONCILIATION:

Please have Mr. Cronin sign and date below acknowledging that you attended the Sacrament of Reconciliation.

Signature and Date: _____

PROJECT # 7

CHRISM OIL

DUE: APRIL 5th

Chrism oil is the matter of the Sacrament of Confirmation, consecrated by the bishop on Holy Thursday at the Chrism Mass (CCC 1297). Chrism is made up of balsam and olive oil (CCC 1289). Balsam is fragrant; a sign of the scent and sweetness of holiness. Olive oil is a sign of eternal life because olive trees do not die.

Oil is significant for many reasons:

- Oil is a sign of abundance and joy.
- Oil was used to limber athletes. This shows how, as soldiers of Christ, we must be prepared at all times.
- Oil was used for healing wounds. Confirmation gives us the graces we need to overcome our wounded nature due to sin.
- Oil was used for nourishment in cooking. Confirmation nourishes our soul with sacramental grace.
- Oil was used for cleansing, to make something beautiful, healthy and strong.

Oil was used throughout the Scriptures for prophets, priests, and kings (CCC 436). In Baptism we came to share in this threefold ministry of Christ (CCC 1241). We are prophets in that we speak the truth. We are priests, that is the common priesthood of the faithful (CCC 1305) by our worshipping God. We are kings by our inheritance to the Kingdom of God. By Confirmation – specifically the anointing – we share more completely in the mission of Jesus Christ and the fullness of the Holy Spirit with which He was filled (CCC 1294), and we are strengthened in these ministries.

QUESTIONS

(Please write your answers on the next page.)

- 1) What is the Matter of a Sacrament?
- 2) Describe the Matter of the Sacrament of Confirmation.
- 3) What is the name of the oil mixture used in Confirmation?
- 4) Of what two parts is it composed?
- 5) What do the two parts of this oil signify?
- 6) When, where (that is, physical location), during which event, and by whom is this oil consecrated?

PROJECT # 7
CHRISM OIL
DUE: APRIL 5th

PROJECT # 8, I
SERVICE AND FAITH ENRICHMENT MINISTRY
(CUMULATIVE 6 HOURS)
DUE: APRIL 26th

*To fulfill your requirement for Service and Faith Enrichment Ministry,
you must spend a cumulative total of six hours in service and/or faith enrichment activity.
Time spent must be carefully logged.*

I. FAITH ENRICHMENT MINISTRY

Faith enrichment is participating in activities that help us grow in our relationship, knowledge, understanding, and love of God and our Catholic faith. Jesus said to his disciples,

“Go therefore and make disciples of all the nations, baptizing them in the name of the Father and the Son and the Holy Spirit, teaching them to observe all that I commanded you; and lo, I am with you always, even to the end of the age” Matthew 28:19-20. As Catholic Christians we are disciples of Jesus, and so we must share the story of salvation with others. Growing in faith with others, especially family members, is a gift that is to be given and received. Here are some suggestions/ideas for how you might grow in faith with others:

- Participate in any or all of the Lenten Mission Retreat Masses/Sacraments at Annunziata: March 28 Mass, 5:00 p.m., March 29 all Masses (7:00, 9:00 and 11:00 a.m.), March 30, 7:00 p.m. Mass followed by Anointing of the Sick, and April 1, 7:00 p.m. Mass followed by Reconciliation. (note: There is no mission on Tuesday, March 30)
- Participate in any Catholic media sources together: watch videos or programs, listen audio books or talks (ex. EWTN, Catholic Radio-96.7 FM or Television).
- Rent, buy or borrow Bishop Robert Barron’s Catholicism Series (it’s incredible) or any of his videos. Listen to his talks or podcasts--available at WordOnFire.com and YouTube.
- Other YouTube resources: FOCUS Catholic, Sensus Fidelium, Catholic Answers, Formed Catholic, EWTN, and many more.
- Read a Catholic book together (Catholic subject, author, saint, general faith enrichment, etc. note: please get approval first). There are many downloadable Catholic books available online.
- Research the saints together (this will help you complete Project #9).
- Read the Bible together.

PLEASE NOTE: The person(s) who participate in the enrichment exercises with you, must also comment on their experience. You are encouraged to share with many people.



**PROJECT # 8, I
FAITH ENRICHMENT MINISTRY**

(CUMULATIVE 6 HOURS)

DUE: APRIL 26TH

STUDENT'S NAME: _____

PARTICIPANT: _____

ENRICHMENT ACTIVITY: _____

DATE: _____ **DURATION:** _____

STUDENT REFLECTION:

PARTICIPANT REFLECTION:

PARTICIPANT SIGNATURE : _____



PROJECT # 8, I
FAITH ENRICHMENT MINISTRY

(CUMULATIVE 6 HOURS)
DUE: APRIL 26TH

STUDENT'S NAME: _____

PARTICIPANT: _____

ENRICHMENT ACTIVITY: _____

DATE: _____ **DURATION:** _____

STUDENT REFLECTION:

PARTICIPANT REFLECTION:

PARTICIPANT SIGNATURE : _____

PROJECT # 8, II
SERVICE MINISTRY
(CUMULATIVE 6 HOURS)
DUE: APRIL 26TH

II. SERVICE

Jesus' said, "I am among you as one who serves." (Luke 22:27) Sincere, self-giving service to others in the form of our time and assistance is a way that we share God's love with others. It gives us a joy that we may not have expected. St. Pope John Paul II called this the Law of the Gift: "But to live our relationships well, we must often make sacrifices, surrendering our own will to serve the good of others. This is why we discover a deeper happiness in life when we give ourselves in this way, for we are living the way God made us to live, which is the way God Himself lives: in total, self-giving, committed love." One of St. Pope John Paul II's favorite lines from Vatican II says, "Man finds himself only by making himself a sincere gift to others."

The service ministry project(s) can be planned from a variety of activities from our parish community, local community, or from a personal experience. It must be completed during the time you are working on this workbook (before April 26th). You may use projects completed during your 8th Grade academic year, but you must write about the experience and get the signature(s) of the person(s) in charge.

The following are suggestions for planning this activity:

- LOCAL COMMUNITY
 - Neighbors or family members who may need help
 - Volunteer at non-profit organizations
 - Stand outside Planned Parenthood clinic to pray silently
- OTHER ACTIVITIES
 - You may come up with your own ideas.
 - You may join in those planned by other parish ministries.

Each candidate must decide how this project will be done. The service time may come from a combination of projects. Upon completion of the service project(s), a reflection must be written describing what the community/service ministry project was about, how this project helped you to become a stronger Catholic Christian, and how it strengthened your commitment to following the example of Jesus. You will need to complete a separate reflection form for each service location. (Please note that the "Signature of Adult in Charge" cannot be a parent.)



PROJECT # 8, II
SERVICE MINISTRY
(CUMULATIVE 6 HOURS)
DUE: APRIL 26TH

STUDENT'S NAME: _____

DATE: _____ **HOURS:** _____

WHERE DID YOU GO? _____

SIGNATURE OF ADULT IN CHARGE: _____

WHAT DID YOU DO and HOW DID YOUR SERVICE HELP OTHERS?

HOW DID YOUR SERVICE HELP YOU BECOME A STRONGER CATHOLIC CHRISTIAN?

HOW DID YOUR SERVICE STRENGTHEN YOUR COMMITMENT TO FOLLOW THE EXAMPLE OF JESUS?



PROJECT # 8, II
SERVICE MINISTRY
(CUMULATIVE 6 HOURS)
DUE: APRIL 26TH

STUDENT'S NAME: _____

DATE: _____ **HOURS:** _____

WHERE DID YOU GO? _____

SIGNATURE OF ADULT IN CHARGE: _____

WHAT DID YOU DO and HOW DID YOUR SERVICE HELP OTHERS?

HOW DID YOUR SERVICE HELP YOU BECOME A STRONGER CATHOLIC CHRISTIAN?

HOW DID YOUR SERVICE STRENGTHEN YOUR COMMITMENT TO FOLLOW THE EXAMPLE OF JESUS?

PROJECT # 9

SAINT (CONFIRMATION) NAME

DUE: APRIL 5th

During the Rite of Confirmation, Father Boehm will call you by your saint's name. Therefore, you will need to select a saint and know their history well, including their virtuous attributes which caused the Catholic Church to honor them with the title Saint.

Choose a saint whose life experience you admire. Begin by researching what a saint is in the eyes of the Catholic Church. Write a report on this saint. The report needs to include the following: name, feast day, a brief history, and the reason why you chose that saint. What do you admire about this saint's life? What cause is this saint famous for?

This saint's name will be the Confirmation name that you will adopt. This 250 to 300 word report should be typed and not be taken lightly. Remember that plagiarism is not tolerated. **Print a copy and bring it to your catechist, Mr. Cronin.**

Use the space below for notes.

PROJECT # 10
CELEBRATION OF THE EUCHARIST
(3 HOMILY REFLECTIONS)
DUE: APRIL 26TH

The Sunday Mass is the gathering of the faithful to pray and give praise to God. During the liturgy we hear the Word of God proclaimed. The Celebrant or deacon shares his thoughts on the Word so that we may take the Word with us as we leave the Church. One way for us to truly live out the Word of God is to spend time reflecting on what these words mean to us.

Each candidate, with the help of his/her parent(s), must write a reflection on the Gospel and homily for three Sunday Masses during the semester.

Suggestions on how to write your reflections:

- You can find the Scripture reference (e.g. Luke 5:1-5) of the Gospel in the bulletin, so be sure to pick up one after Mass.
- Discuss what you heard and write it down on the way home in the car, asking everyone to participate.
- Ask yourself and your family what the Scripture and homily has to do with your life today.
- When you get home, write your reflection in your workbook while it is fresh in your mind.

Remember, this is a personal reflection; what you write is what you feel the Scripture is saying to YOU at this moment in your life's journey.

There is a completed sample Sunday Mass reflection form on the next page, which is provided so you can have an idea of what you might take from the Gospel and homily. Following the sample page are three blank Sunday Mass reflection forms for you to complete.

PROJECT # 10
CELEBRATION OF THE EUCHARIST
DUE: APRIL 26TH

SAMPLE
SUNDAY MASS REFLECTION

DATE: January 6 Epiphany

TIME: 9:00 a.m. Mass

NAME): Father Jack McEvilly

GOSPEL EVANGELIST: Matthew

CHAPTER & VERSE: 2:1-11

BRIEF SUMMARY OF THE GOSPEL:

The Magi come searching for the King of the Jews. They followed a star and found Jesus in the city of Bethlehem. They offered Him gifts of gold, frankincense and myrrh.

REFLECTION ON WHAT THE GOSPEL MEANS FOR YOU:

HOW DOES IT CHALLENGE YOU AND YOUR LIFESTYLE?

It makes me ask the question of how faithful I am in following and searching for Jesus in my own life.

The Kings come to Jesus through a star whose light lead them. How do I come to Jesus, what leads me to Him? Parents, Church, friends, nature? What are the signs that direct me to Jesus and allow me to proclaim Him the King, the Lord and truth of my life?

The Gospel also makes me ask—what are the gifts that I offer to Jesus? How willing am I to offer them to Jesus or other people? I guess my gift is my time with family, especially when I help out at home.

Also my being respectful of other people, especially if they are different from me.

Most importantly it is to be like the Kings and listen to how God calls me to come to Him, to follow Him. So I know that it is important to make sure I pray every day and go to Mass.

PROJECT # 10
CELEBRATION OF THE EUCHARIST
DUE: APRIL 26th

SUNDAY MASS REFLECTION

DATE: _____ TIME: _____

CELEBRANT (PRIEST'S NAME): _____

GOSPEL EVANGELIST: _____ CHAPTER & VERSE: _____

BRIEF SUMMARY OF THE GOSPEL:

REFLECTION ON WHAT THE GOSPEL MEANS FOR YOU:

HOW DOES IT CHALLENGE YOU AND YOUR LIFESTYLE?

PROJECT # 10
CELEBRATION OF THE EUCHARIST

DUE: APRIL 26TH

SUNDAY MASS REFLECTION

DATE: _____ **TIME:** _____

CELEBRANT (PRIEST'S NAME): _____

GOSPEL EVANGELIST: _____ **CHAPTER & VERSE:** _____

BRIEF SUMMARY OF THE GOSPEL:

REFLECTION ON WHAT THE GOSPEL MEANS FOR YOU:

HOW DOES IT CHALLENGE YOU AND YOUR LIFESTYLE?

PROJECT # 10
CELEBRATION OF THE EUCHARIST
DUE: APRIL 26TH

SUNDAY MASS REFLECTION

DATE: _____ **TIME:** _____

CELEBRANT (PRIEST'S NAME): _____

GOSPEL EVANGELIST: _____ **CHAPTER & VERSE:** _____

BRIEF SUMMARY OF THE GOSPEL:

REFLECTION ON WHAT THE GOSPEL MEANS FOR YOU:

HOW DOES IT CHALLENGE YOU AND YOUR LIFESTYLE?

PROJECT # 11
CONFIRMATION SHIELD

DUE: APRIL 26th

You write →

A virtue you see in your parents and why you would like to develop this virtue.

Your parents write →

A virtue your parents see in you and how they think it affects your life.

In the middle, you will put a picture of yourself with your saint name above the picture, last name below.

Name 1
thing you would like to be when you are older, and how courage will help you attain this.

You write →

Name 3 ways you hope to witness Christ in your life.

You write →

A quote of your choice from your saint. ← *You choose*

You may decorate with anything you want: wrapping paper, scrapbook materials, stickers, markers, yarn, glitter, etc. You provide supplies.

PROJECT # 11
CONFIRMATION SHIELD

DUE: APRIL 26th

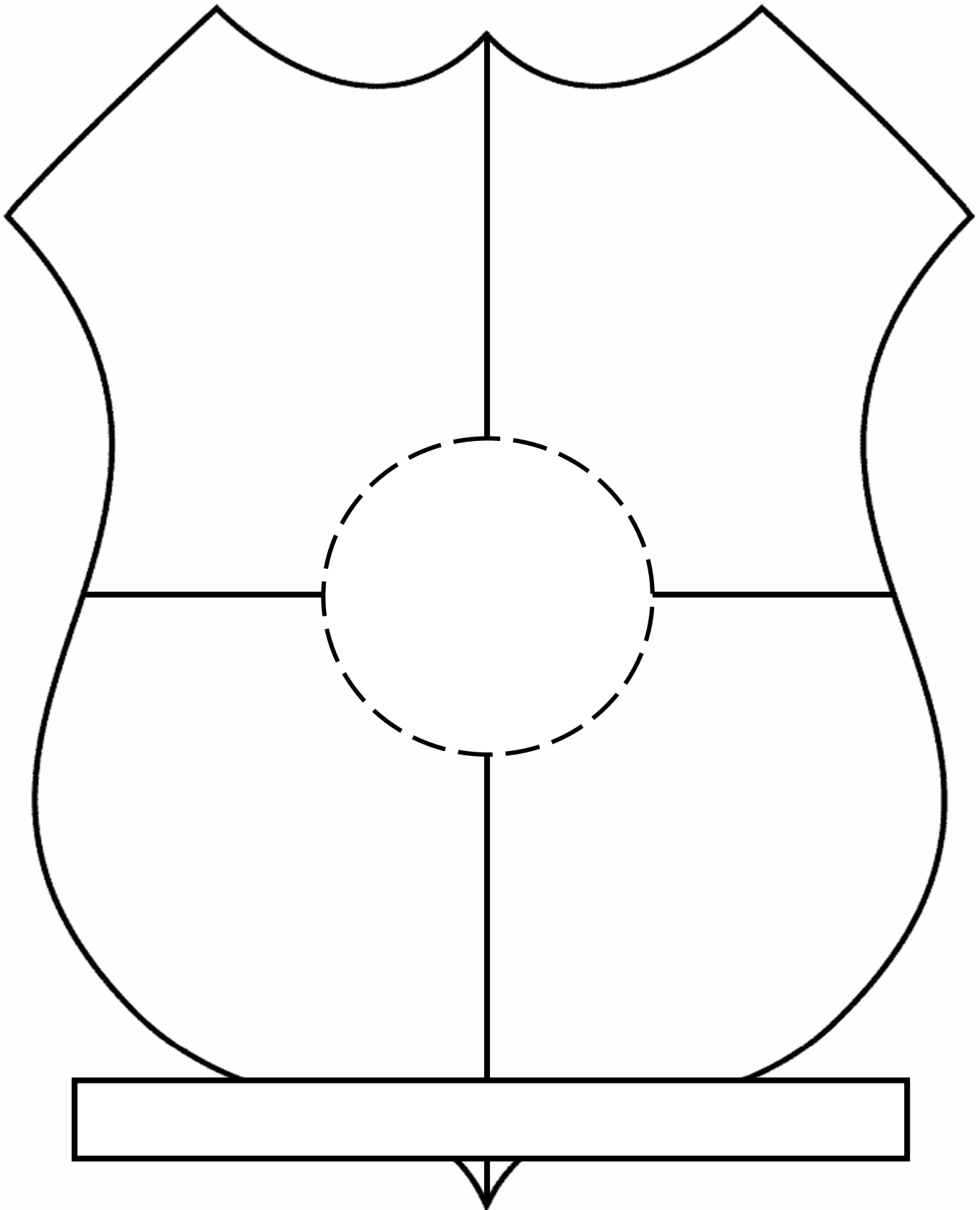

PROJECT # 11
CONFIRMATION SHIELD

DUE: APRIL 26th

